



Summit Switch Hardware Installation Guide

Extreme Networks, Inc.

3585 Monroe Street

Santa Clara, California 95051

(888) 257-3000

<http://www.extremenetworks.com>

Published: December 2000
Part number: 100037-00 Rev. C

©2000 Extreme Networks, Inc. All rights reserved. Extreme Networks and BlackDiamond are registered trademarks of Extreme Networks, Inc. in the United States and certain other jurisdictions. ExtremeWare, ExtremeWare Vista, ExtremeWorks, ExtremeAssist, ExtremeAssist1, ExtremeAssist2, PartnerAssist, Extreme Standby Router Protocol, ESRP, SmartTraps, Alpine, Summit, Summit1i, Summit4, Summit4/FX, Summit5i, Summit7i, Summit24, Summit48, Summit48i, Summit Virtual Chassis, SummitLink, SummitGbX, SummitRPS and the Extreme Networks logo are trademarks of Extreme Networks, Inc., which may be registered or pending registration in certain jurisdictions. The Extreme Turbodriven logo is a service mark of Extreme Networks, which may be registered or pending registration in certain jurisdictions. All other registered trademarks, trademarks and service marks are property of their respective owners. Specifications are subject to change without notice.

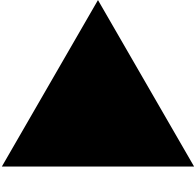

Contents

Preface	
Introduction	xi
Conventions	xii
Related Publications	xiii
1 Summit Switch Overview	
Summit Switch Models	1-1
Summary of Features	1-2
Memory Requirements	1-3
Port Connections	1-3
Full-Duplex	1-6
Summit4 Switch Front View	1-7
Summit4/FX Switch Front View	1-8
Summit24 Switch Front View	1-9
Summit48 Switch Front View	1-10
Summit4, Summit24, and Summit48 Switch Rear View	1-11
Power Socket	1-11
Serial Number	1-11
Console Port	1-11
Redundant Power Supply Port	1-11
MAC Address	1-12

Reset Button	1-12
Summit4, Summit24, and Summit48 Switch LEDs	1-12
Summit1i Switch Front View	1-14
Summit1i Switch Rear View	1-15
Power Sockets	1-15
Serial Number	1-16
MAC Address	1-16
Reset Button	1-16
Console Port	1-16
Summit5i Switch Front View	1-17
Summit5i Switch Rear View	1-19
Power Sockets	1-19
Serial Number	1-19
MAC Address	1-19
Reset Button	1-20
Console Port	1-20
Management Port	1-20
Summit7i Switch Front View	1-21
Reset Button	1-23
Console Port	1-23
Modem Port	1-23
Management Port	1-23
PCMCIA Slot	1-23
Summit7i Switch Rear View	1-24
Power Sockets	1-24
Serial Number	1-24
MAC Address	1-24
Summit48i Switch Front View	1-25
Summit48i Switch Rear View	1-26
Power Sockets	1-26
Serial Number	1-26
MAC Address	1-26
Reset Button	1-27
Console Port	1-27

Summit1i, Summit5i, Summit7i, and Summit48i Switch LEDs	1-27
GBIC Type and Hardware/Software Support	1-28
2 Installation and Setup	
Following Safety Information	2-1
Determining the Switch Location	2-1
Installing the Summit Switch	2-2
Rack Mounting	2-2
Free-Standing	2-5
Stacking the Switch and Other Devices	2-5
Connecting Equipment to the Console Port	2-5
Powering On the Switch	2-7
Checking the Installation	2-7
Logging In for the First Time	2-8
Installing the Gigabit Interface Connector (GBIC)	2-9
A Safety Information	
Important Safety Information	A-1
Power	A-1
Power Cord	A-2
Fuse	A-2
Connections	A-3
Lithium Battery	A-3
B Technical Specifications	
Summit4, Summit4/FX, Summit24, and Summit48 Switch Specifications	B-1
Summit1i, Summit5i, Summit7i, and Summit48i Switch Specifications	B-2
Index	

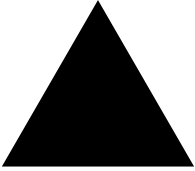

Figures

1-1	Summit4 switch front view	1-7
1-2	Summit4/FX switch front view	1-8
1-3	Summit24 switch front view	1-9
1-4	Summit48 switch front view	1-10
1-5	Summit switch rear view	1-11
1-6	Front view of Summit1i switch with 100BASE-TX/ 1000BASE-T ports	1-14
1-7	Front view of Summit1i switch with 1000BASE-SX ports	1-14
1-8	Summit1i switch rear view	1-15
1-9	Front view of Summit5i switch with 100BASE-TX/ 1000BASE-T ports	1-17
1-10	Front view of Summit5i switch with 1000BASE-SX ports	1-17
1-11	Front view of Summit5i switch with 1000BASE-LX ports	1-18
1-12	Summit5i switch rear view	1-19
1-13	Front view of Summit7i switch with 100BASE-TX/ 1000BASE-T ports	1-21
1-14	Front view of Summit7i switch with 1000BASE-SX ports	1-22
1-15	Summit7i switch rear view	1-24
1-16	Front view of Summit48i switch	1-25
1-17	Summit48i switch rear view	1-26
2-1	Rack-mount helper bracket	2-3
2-2	Fitting the mounting bracket	2-4
2-3	Null-modem cable pin-outs	2-6
2-4	PC-AT serial null-modem cable pin-outs	2-7
2-5	GBIC modules	2-9

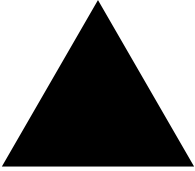

Tables

1	Notice Icons	xii
2	Text Conventions	xii
1-1	Summit Switch Port Configurations	1-4
1-2	Media Types and Distances	1-5
1-3	1000BASE-LX70 Specifications	1-6
1-4	Summit4, Summit24, and Summit48 Switch LED Behavior	1-12
1-5	Summit1i, Summit5i, Summit7i, and Summit48i Switch LED Behavior	1-27
2-1	Console Connector Pinouts	2-6

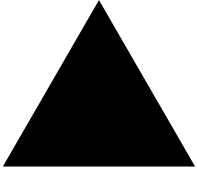

Preface

This Preface provides an overview of this guide, describes guide conventions, and lists other publications that might be useful.

Introduction

This guide provides the required information to install the Summit™ switch.

This guide is intended for use by network administrators who are responsible for installing and setting up network equipment. It assumes a basic working knowledge of the following:

- Local Area Networks (LANs)
- Ethernet concepts
- Ethernet switching and bridging concepts
- Routing concepts
- Simple Network Management Protocol (SNMP)

For information on configuring the Summit switch, refer to the *ExtremeWare Software User Guide*.



Note: If the information in the Release Notes shipped with your switch differs from the information in this guide, follow the Release Notes.

Conventions

Table 1 and Table 2 list conventions used throughout this guide.

Table 1: Notice Icons



Icon	Notice Type	Alerts you to...
	Note	Important features or instructions.
	Caution	Risk of personal injury, system damage, or loss of data.
	Warning	Risk of severe personal injury.

Table 2: Text Conventions

Convention	Description
Screen displays	This typeface represents information as it appears on the screen, or command syntax.
Screen displays bold	This typeface represents commands that you type.
The words “enter” and “type”	When you see the word “enter” in this guide, you must type something, and then press the Return or Enter key. Do not press the Return or Enter key when an instruction simply says “type.”
[Key] names	Key names appear in text in one of two ways: <ul style="list-style-type: none"> ■ Referred to by their labels, such as “the Return key” or “the Escape key” ■ Written with brackets, such as [Return] or [Esc] If you must press two or more keys simultaneously, the key names are linked with a plus sign (+). Example: Press [Ctrl]+[Alt]+[Del].
Words in <i>italicized type</i>	Italics emphasize a point or denote new terms at the place where they are defined in the text.

Related Publications

The Summit switch documentation set includes the following:

- *ExtremeWare Software User Guide*
- *ExtremeWare Quick Reference Guide*
- ExtremeWare Release Notes

Documentation for Extreme Networks products is available on the World Wide Web at the following location:

- Extreme Networks home page <http://www.extremenetworks.com/>



Summit Switch Overview

This chapter describes the following:

- Summit switch models
- Summit switch features
- Summit switch memory requirements
- Summit switch front views
- Summit switch rear views
- Summit switch LEDs
- Factory default settings

Summit Switch Models

The following models comprise the Summit family of switches:

- Summit4 switch
- Summit4/FX switch
- Summit24 switch
- Summit48 switch
- Summit1i switch
- Summit5i switch
- Summit7i switch

- Summit48i switch

Summary of Features

Summit switches support the following ExtremeWare features:

- Virtual local area networks (VLANs) including support for IEEE 802.1Q and IEEE 802.1p
- VLAN aggregation
- Spanning Tree Protocol (STP) (IEEE 802.1D) with multiple STP domains
- Policy-Based Quality of Service (PB-QoS)
- Wire-speed Internet Protocol (IP) routing
- IP Multinetting
- DHCP/BOOTP Relay
- Extreme Standby Router Protocol (ESRP)
- Routing Information Protocol (RIP) version 1 and RIP version 2
- Open Shortest Path First (OSPF) routing protocol
- Border Gateway Protocol (BGP) version 4
- IPX routing, including RIP and Service Advertisement Protocol (SAP)
- Wire-speed IP multicast routing support
- Diffserv support
- Access-policy support for routing protocols
- Access list support for packet filtering
- IGMP snooping to control IP multicast traffic
- Distance Vector Multicast Routing Protocol (DVMRP)
- Protocol Independent Multicast-Dense Mode (PIM-DM)
- Protocol Independent Multicast-Sparse Mode (PIM-SM)
- Wire-speed IPX, IPX/RIP, and IPX/SAP support
- Server Load Balancing (SLB) support
- RADIUS client and per-command authentication support
- TACACS+ support

- Console command-line interface (CLI) connection
- Telnet CLI connection
- SSH2 connection
- ExtremeWare Vista Web-based management interface
- Simple Network Management Protocol (SNMP) support
- Remote Monitoring (RMON)

Memory Requirements

Your “/” series Summit switch must have 32 MB of DRAM in order to support the features in ExtremeWare version 4.0 and above. This is not an issue for Summit24 and Summit48 switch models, and all currently shipping switches contain 32 MB. Some earlier models of the Summit switch shipped with 16 MB, and must be upgraded to support ExtremeWare version 4.0 and above.

To determine the memory size in your switch, use the following command:

```
show memory
```

For Summit switches running ExtremeWare 4.0 and above, the switch indicates the total DRAM size in megabytes as part of the output. For Summit switches running previous ExtremeWare releases, you must calculate the memory by taking the sum of the bytes listed under `current free` and adding to it the bytes listed under `current alloc`. If the sum is greater than 16,000,000, there is no need to upgrade the memory on the switch. If this is not the case, please contact your supplier.

Port Connections

The major difference between the models of the Summit switch is the port configurations on each switch model. Summit switches use a combination of the following types of ports:

- 1000BASE-SX ports using 850 nm duplex SC connectors
- 1000BASE-LX ports using 1300 nm duplex SC connectors
- 1000BASE-SX ports using MT-RJ connectors
- 1000BASE-LX ports using MT-RJ connectors

- Modular 1000BASE-SX and 1000BASE-LX using Gigabit Interface Connectors (GBICs)
- 10BASE-T/100BASE-TX ports using RJ-45 connectors
- 100BASE-FX ports using 1300 nm duplex SC connectors
- 100BASE-TX/1000BASE-T ports using RJ-45 connectors

Table 1-1 describes port configurations available on the different Summit switch models.

Table 1-1: Summit Switch Port Configurations

Switch Model	Ethernet Ports						
	1000BASE -SX	1000BASE -LX	100/1000 BASE-T	GBIC	Redun- dant GBIC	10BASE-T/ 100BASE- TX	100BASE -FX
Summit4	6					16	
Summit4/FX	6						16
Summit24				1	1	24	
Summit48				2	2	48	
Summit1i (SX)	6			2			
Summit1i (TX)			6	2			
Summit5i (SX)	12			4			
Summit5i (LX)		12		4			
Summit5i (TX)			12	4			
Summit7i (SX)	28			4			
Summit7i (TX)			28	4			
Summit48i (TX)				2	2	48	

Media Types and Distances

Table 1-2 describes the media types and distances for the different types of Summit switch ports.

Table 1-2: Media Types and Distances

Standard	Media Type	MHz•km Rating	Maximum Distance (Meters)
1000BASE-SX (850 nm optical window)	50/125 μ m Multimode Fiber	400	500
	50/125 μ m Multimode Fiber	500	550
	62.5/125 μ m Multimode Fiber	160	220
	62.5/125 μ m Multimode Fiber	200	275
1000BASE-LX (1300 nm optical window)	50/125 μ m Multimode Fiber	400	550
	50/125 μ m Multimode Fiber	500	550
	62.5/125 μ m Multimode Fiber	500	550
	10/125 μ m Single-mode Fiber	–	5,000
1000BASE-LX (1300 nm optical window)	10/125 μ m Single-mode Fiber*	–	10,000
	10/125 μ m Single-mode Fiber	–	70,000
100BASE-FX (1300 nm optical window)	50/125 μ m Multimode Fiber	400	2000
	50/125 μ m Multimode Fiber	500	2000
	62.5/125 μ m Multimode Fiber	400	2000
	62.5/125 μ m Multimode Fiber	500	2000
1000BASE-T	Category 5 and higher UTP Cable	–	100
100BASE-TX	Category 5 and higher UTP Cable	–	100
10BASE-T	Category 3 and higher UTP Cable	–	100

*Extreme Networks proprietary. Connections between two Extreme Networks 1000BASE-LX interfaces can use a maximum distance of 10,000 meters. However, it interoperates with standard 1000BASE-LX ports and supports a maximum distance of 5,000 meters.

Table 1-3 describes the specifications for the 1000BASE-LX70 interface.

Table 1-3: 1000BASE-LX70 Specifications

Parameter	Minimum	Typical	Maximum
Transceiver			
Optical Output Power	0 dBm	3 dBm	5 dBm*
Center Wavelength	1540 nm	1550 nm	1560 nm
Receiver			
Optical Input Power Sensitivity	-20 dBm		
Optical Input Power Maximum			-3 dBm
Operating Wavelength	1200 nm		1560 nm

*The transmitter output power level for the 1000BASE-LX70 is +5 dBm. The maximum allowable receiver input power level is -3 dBm. Therefore, there is a minimum of 8 dB loss required for the link to operate without errors. This minimum required loss can be achieved using a fiber length of 32 km (0.25 dB/km provides 8 dB loss), or by adding 10 dB of fixed optical attenuator at the receiver end.

Full-Duplex

The Summit switch provides full-duplex support for all ports. Full-duplex allows frames to be transmitted and received simultaneously and, in effect, doubles the bandwidth available on a link. All 10/100/1000 Mbps ports on the Summit switch autonegotiate for half- or full-duplex operation. Gigabit Ethernet and 100BASE-FX ports operate in full-duplex mode, only.

Summit4 Switch Front View

Figure 1-1 shows the Summit4 switch front view.

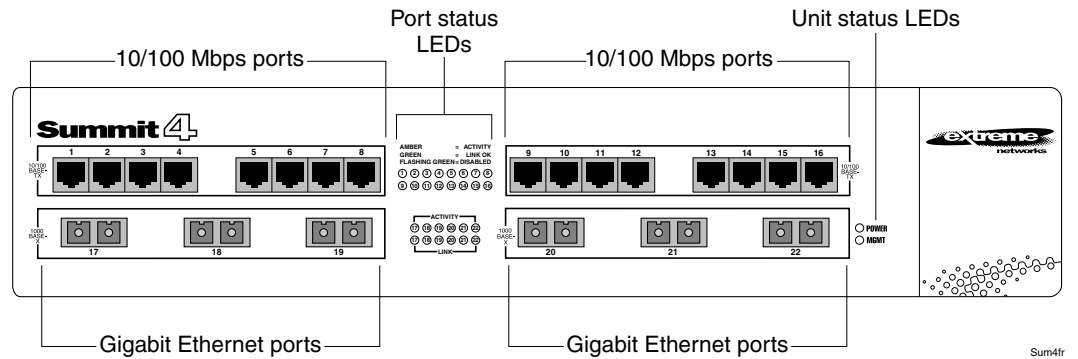

Figure 1-1: Summit4 switch front view

The Summit4 switch has 16 autosensing 10BASE-T/100BASE-TX ports and 6 Gigabit Ethernet ports. The Gigabit Ethernet ports use standard SC connectors and support 1000BASE-SX over multimode fiber-optic cable.



Note: For information on supported media types and distances, refer to Table 1-2 on page 1-5.



Note: For information on Summit switch LEDs, refer to “Summit4, Summit24, and Summit48 Switch LEDs,” on page 1-12.

Summit4/FX Switch Front View

Figure 1-2 shows the Summit4/FX switch front view.

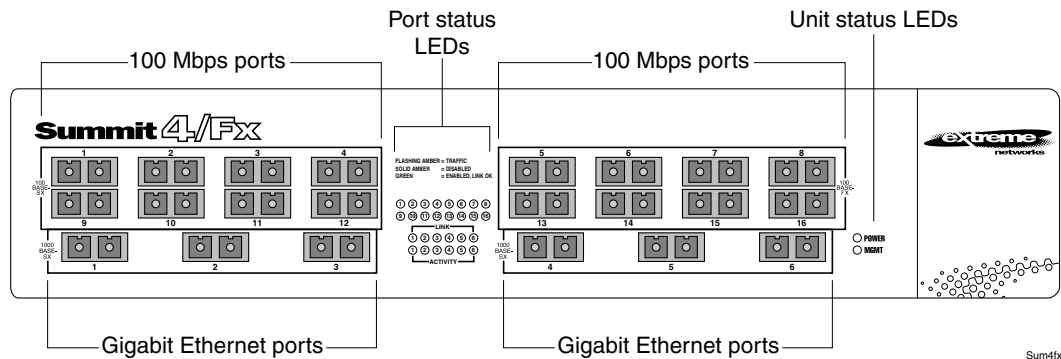

Figure 1-2: Summit4/FX switch front view

The Summit4/FX switch has 16 100BASE-FX ports and 6 Gigabit Ethernet ports. All ports use standard SC connectors. The Gigabit Ethernet ports support 1000BASE-SX over multimode fiber-optic cable.



Note: For information on supported media types and distances, refer to Table 1-2 on page 1-5.



Note: For information on Summit switch LEDs, refer to “Summit4, Summit24, and Summit48 Switch LEDs,” on page 1-12.

Summit24 Switch Front View

Figure 1-3 shows the Summit24 switch front view.

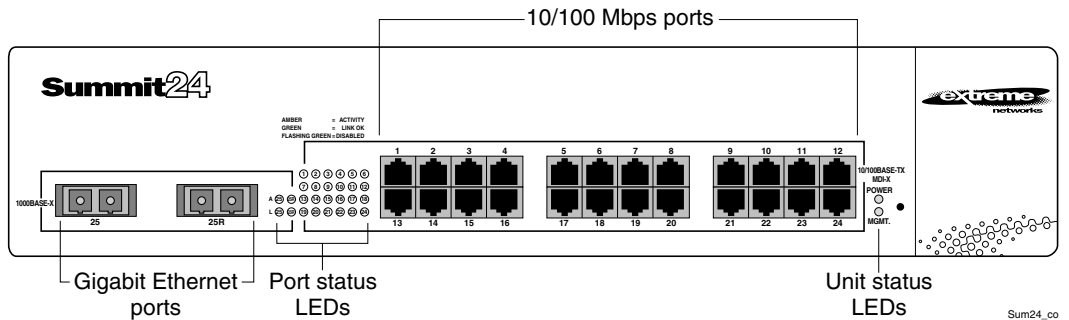

Figure 1-3: Summit24 switch front view

The Summit24 switch has 24 autosensing 10BASE-T/100BASE-TX ports, one Gigabit Ethernet port, and one redundant Gigabit Ethernet port.



Note: For information on supported media types and distances, refer to Table 1-2 on page 1-5.



Note: For information on Summit switch LEDs, refer to “Summit4, Summit24, and Summit48 Switch LEDs,” on page 1-12.

Summit48 Switch Front View

Figure 1-4 shows the Summit48 switch front view.

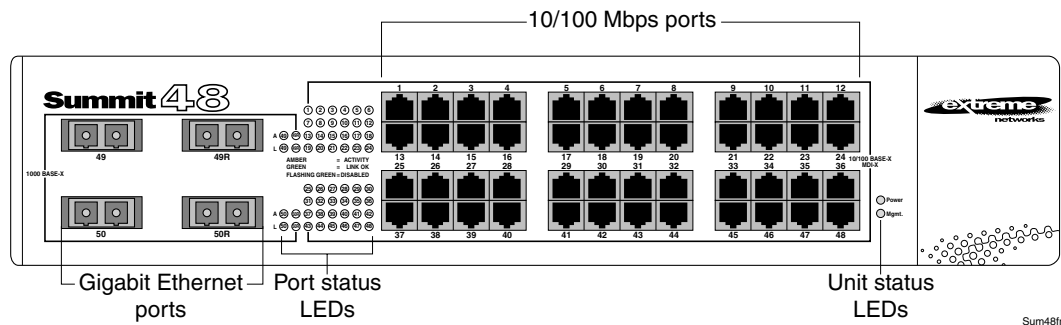

Figure 1-4: Summit48 switch front view

The Summit48 switch has 48 autosensing 10BASE-T/100BASE-TX ports, 2 Gigabit Ethernet ports, and 2 redundant Gigabit Ethernet ports. All the Gigabit Ethernet ports use GBIC connectors.



Note: For information on supported media types and distances, refer to Table 1-2 on page 1-5.



Note: For information on Summit switch LEDs, refer to “Summit4, Summit24, and Summit48 Switch LEDs,” on page 1-12.

Summit4, Summit24, and Summit48 Switch Rear View

Figure 1-5 shows the rear view for the Summit4, Summit4/FX, Summit24, and Summit48 switches.

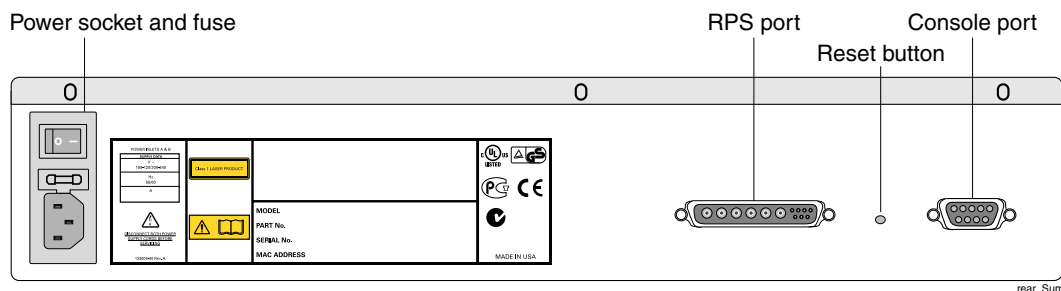

Figure 1-5: Summit switch rear view

Power Socket

The Summit switch automatically adjusts to the supply voltage. The power supply operates down to 90 V. The fuse is suitable for both 110 VAC and 220-240 VAC operation.

Serial Number

Use this serial number for fault-reporting purposes.

Console Port

Use the console port (9-pin, “D” type connector) for connecting a terminal and carrying out local management.

Redundant Power Supply Port

The redundant power supply (RPS) port is used to connect to a Summit RPS. The Summit RPS provides a redundant, load-shared power source to the Summit. If the primary power source for the switch fails, the RPS takes over, ensuring uninterrupted network operation.

When connected to a Summit RPS, the Summit switch can provide status on power and fan operation of the RPS through SNMP, the command-line interface, and the Web interface.

The Summit RPS can simultaneously provide power for as many as two Summit switches.

MAC Address

This label shows the unique Ethernet MAC address assigned to this device.

Reset Button

The reset button is used to hard reset the switch. Use a non-conductive tool to push the reset button.

Summit4, Summit24, and Summit48 Switch LEDs

Table 1-4 describes the light emitting diode (LED) behavior on the Summit4, Summit4/FX, Summit24, and Summit48 switches.

Table 1-4: Summit4, Summit24, and Summit48 Switch LED Behavior

Unit Status LEDs

LED	Color	Indicates
Power	Green	The Summit switch is powered up.
	Yellow	The Summit switch is indicating a power, overheat, or fan failure.
MGMT	Green flashing	
	■ Slow	The Summit switch is operating normally.
	■ Fast	Power On Self Test (POST) or software download in progress.
	Yellow	The Summit has failed its POST.

Table 1-4: Summit4, Summit24, and Summit48 Switch LED Behavior (continued)

10/100 Mbps Port Status LEDs

Color	Indicates
Green	Link is present; port is enabled.
Yellow	Frames are being transmitted/received on this port.
Green flashing	Link is present; port is disabled.
Off	Link is not present.

Gigabit Ethernet Port Status LEDs

LED	Color	Indicates
Packet	Yellow	Frames are being transmitted/received on this port.
	Off	No activity on this port.
Status	Green on	Link is present; port is enabled; full-duplex operation.
	Green flashing	Link is present; port is disabled.
	Off	Link is not present.

Summit1i Switch Front View

The Summit1i switch ships in one of two port configurations:

- 6 autosensing 100BASE-TX/1000BASE-T ports
- 6 1000BASE-SX ports

Figure 1-6 shows the front view of the Summit1i switch with 100BASE-TX/1000BASE-T ports.

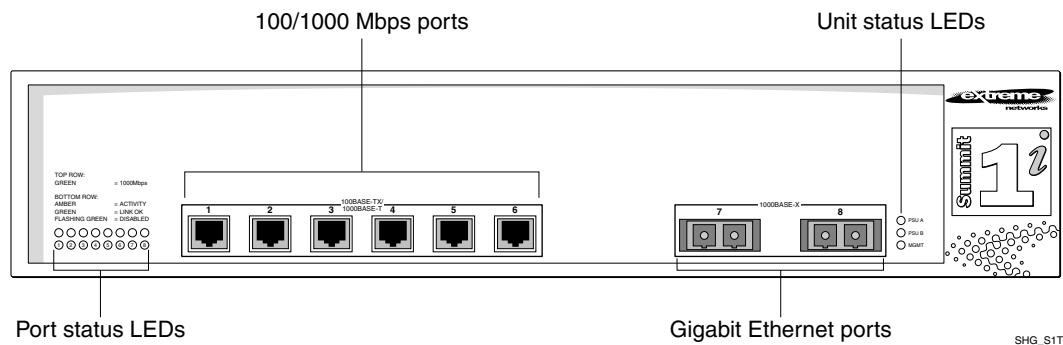

Figure 1-6: Front view of Summit1i switch with 100BASE-TX/1000BASE-T ports

Figure 1-7 shows the front view of the Summit1i switch with 1000BASE-SX ports. These ports use MT-RJ connectors.

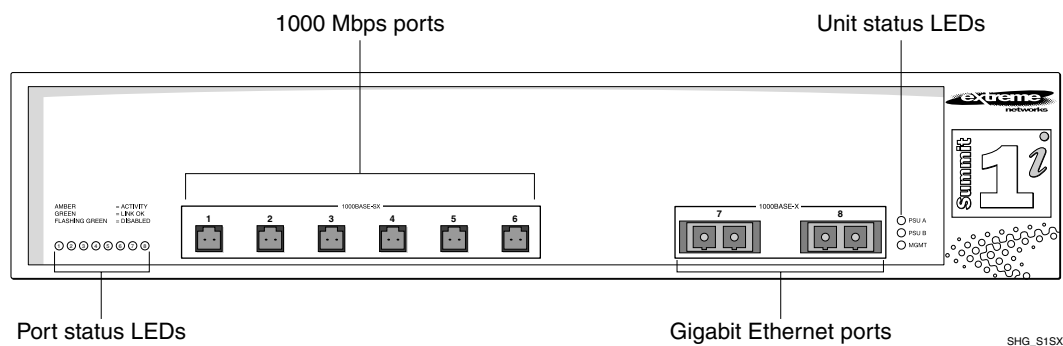

Figure 1-7: Front view of Summit1i switch with 1000BASE-SX ports

Both Summit1i switch models also provide two unpopulated GBIC ports with SC connectors. You can use any of the following GBICs in the Summit1i switch:

- 1000BASE-SX
- 1000BASE-LX
- 1000BASE-LX70



Note: For information on GBICs, refer to “GBIC Type and Hardware/Software Support,” on page 1-28.



Note: For information on supported media types and distances, refer to Table 1-2 on page 1-5.



Note: For information on Summit1i switch LEDs, refer to “Summit1i, Summit5i, Summit7i, and Summit48i Switch LEDs,” on page 1-27.

Summit1i Switch Rear View

Figure 1-8 shows the rear view for the Summit1i switch.

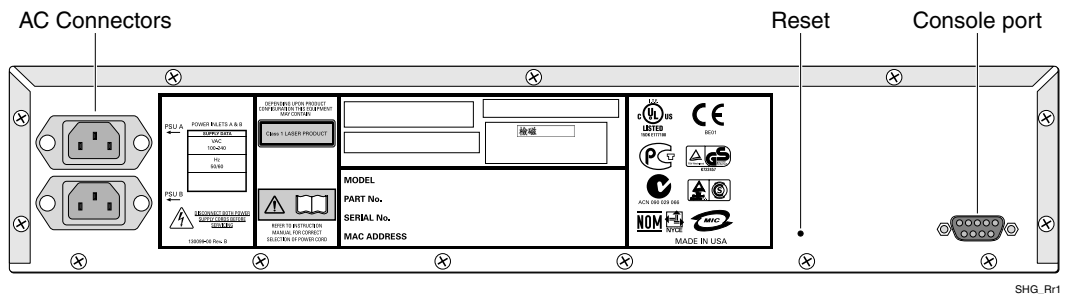

Figure 1-8: Summit1i switch rear view

Power Sockets

The Summit1i switch supports up to two power supplies. Each power supply has its own power socket. When a second power supply is installed, both provide a redundant,

load-shared power source to the Summit1i switch. If one of the power sources fails, the second power supply takes over, ensuring uninterrupted network operation.



Note: Summit1i switch power supplies must be serviced by personnel trained by Extreme Networks, only.

Serial Number

The serial number is used for fault-reporting purposes.

MAC Address

This label shows the unique Ethernet MAC address assigned to this device.

Reset Button

The reset button is used to hard reset the switch. Use a non-conductive tool to push the reset button.

Console Port

The console port (9-pin, “D” type connector) is used for connecting a terminal and carrying out local management.

Summit5i Switch Front View

The Summit5i switch ships in one of three port configurations:

- 12 autosensing 100BASE-TX/1000BASE-T ports
- 12 1000BASE-SX ports
- 12 1000BASE-LX ports

Figure 1-9 shows the front view of the Summit5i switch with 100BASE-TX/1000BASE-T ports.

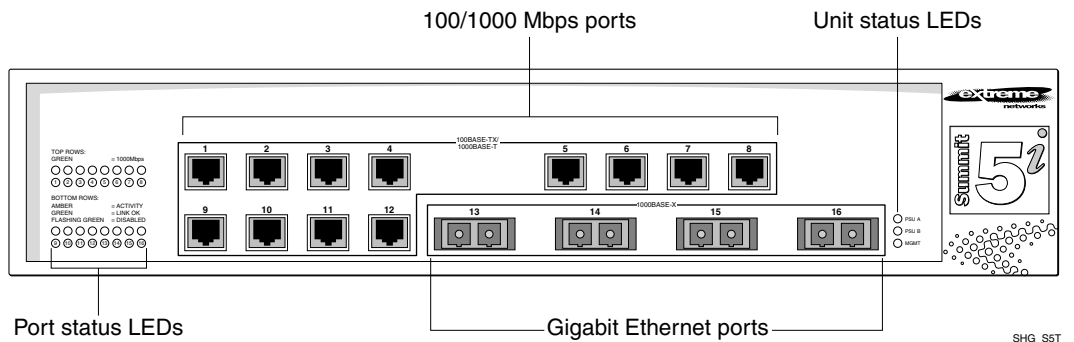

Figure 1-9: Front view of Summit5i switch with 100BASE-TX/1000BASE-T ports

Figure 1-10 shows the front view of the Summit5i switch with 1000BASE-SX ports. These ports use MT-RJ connectors.

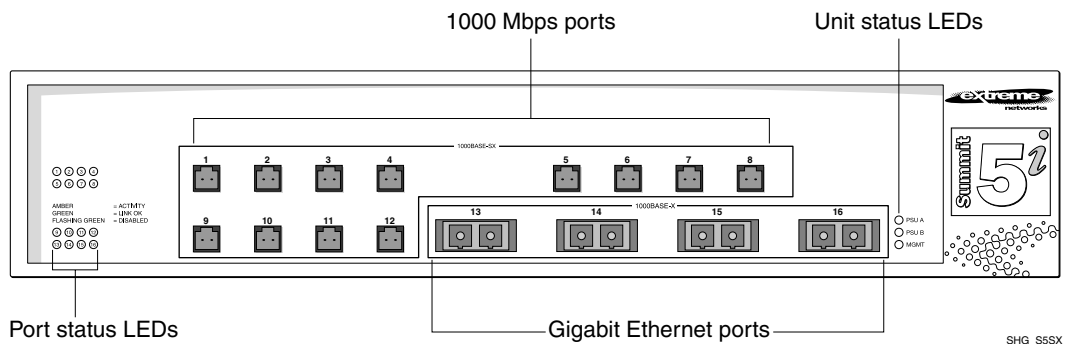

Figure 1-10: Front view of Summit5i switch with 1000BASE-SX ports

Figure 1-11 shows the front view of the Summit5i switch with 1000BASE-LX ports. These ports use MT-RJ connectors.

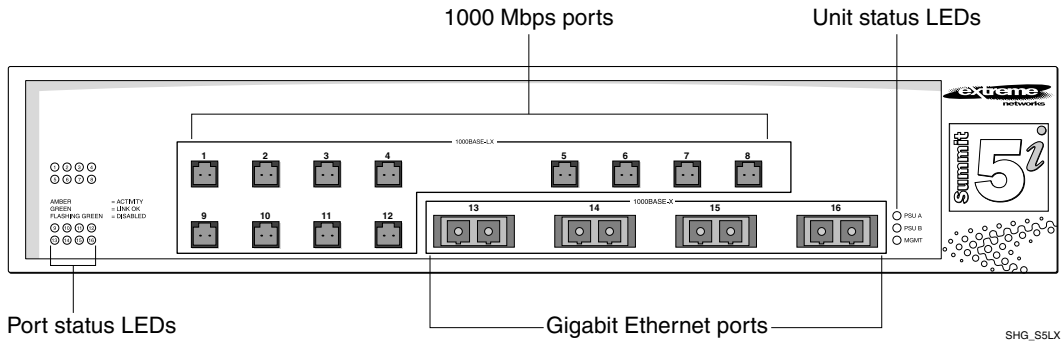

Figure 1-11: Front view of Summit5i switch with 1000BASE-LX ports

All three Summit5i switch models also provide four unpopulated GBIC ports with SC connectors. You can use any of the following GBICs in the Summit5i switch:

- 1000BASE-SX
- 1000BASE-LX
- 1000BASE-LX70



Note: For information on GBICs, refer to “GBIC Type and Hardware/Software Support,” on page 1-28.



Note: For information on supported media types and distances, refer to Table 1-2 on page 1-5.



Note: For information on Summit5i switch LEDs, refer to “Summit1i, Summit5i, Summit7i, and Summit48i Switch LEDs,” on page 1-27.

Summit5i Switch Rear View

Figure 1-12 shows the rear view for the Summit5i switch.

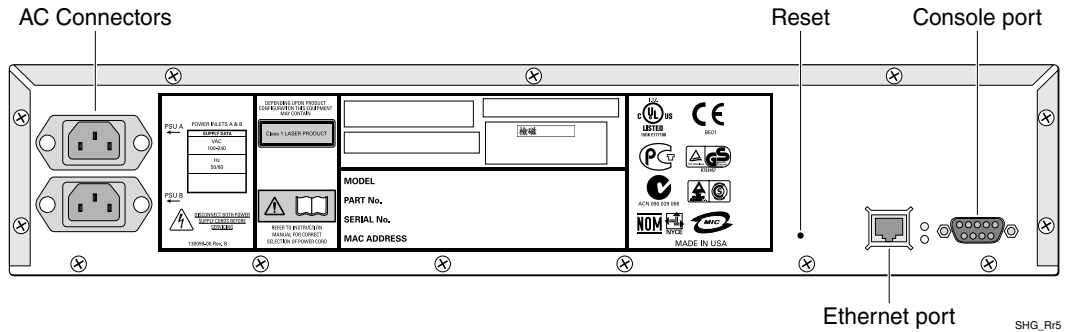

Figure 1-12: Summit5i switch rear view

Power Sockets

The Summit5i switch supports up to two power supplies. Each power supply has its own power socket. When a second power supply is installed, both provide a redundant, load-shared power source to the Summit5i switch. If one of the power sources fails, the second power supply takes over, ensuring uninterrupted network operation.



Note: Summit5i switch power supplies must be serviced by personnel trained by Extreme Networks, only.

Serial Number

The serial number is used for fault-reporting purposes.

MAC Address

This label shows the unique Ethernet MAC address assigned to this device.

Reset Button

The reset button is used to hard reset the switch. Use a non-conductive tool to push the reset button.

Console Port

The console port (9-pin, “D” type connector) is used for connecting a terminal and carrying out local management.

Management Port

The management port (RJ-45 connector) is a 10/100 Mbps Ethernet connection used for out-of-band management.

Summit7i Switch Front View

The Summit7i switch ships in one of two port configurations:

- 28 autosensing 100BASE-TX/1000BASE-T ports
- 28 1000BASE-SX ports

Figure 1-13 shows the front view of the Summit7i switch with 100BASE-TX/1000BASE-T ports.

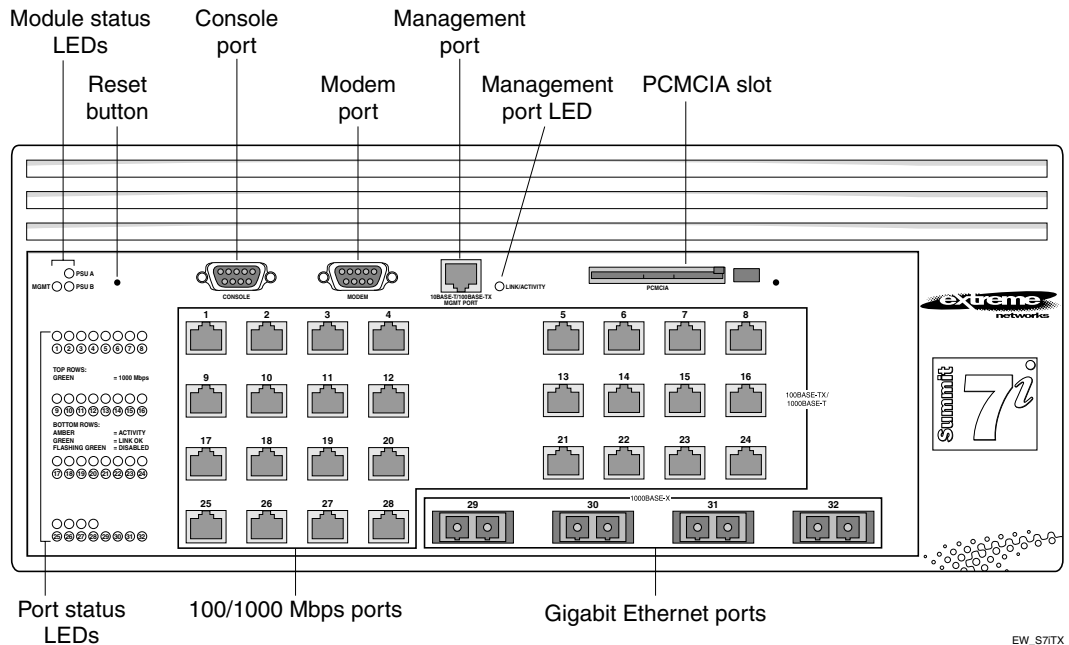

Figure 1-13: Front view of Summit7i switch with 100BASE-TX/1000BASE-T ports

Figure 1-14 shows the front view of the Summit7i switch with 1000BASE-SX ports. These ports use MT-RJ connectors.

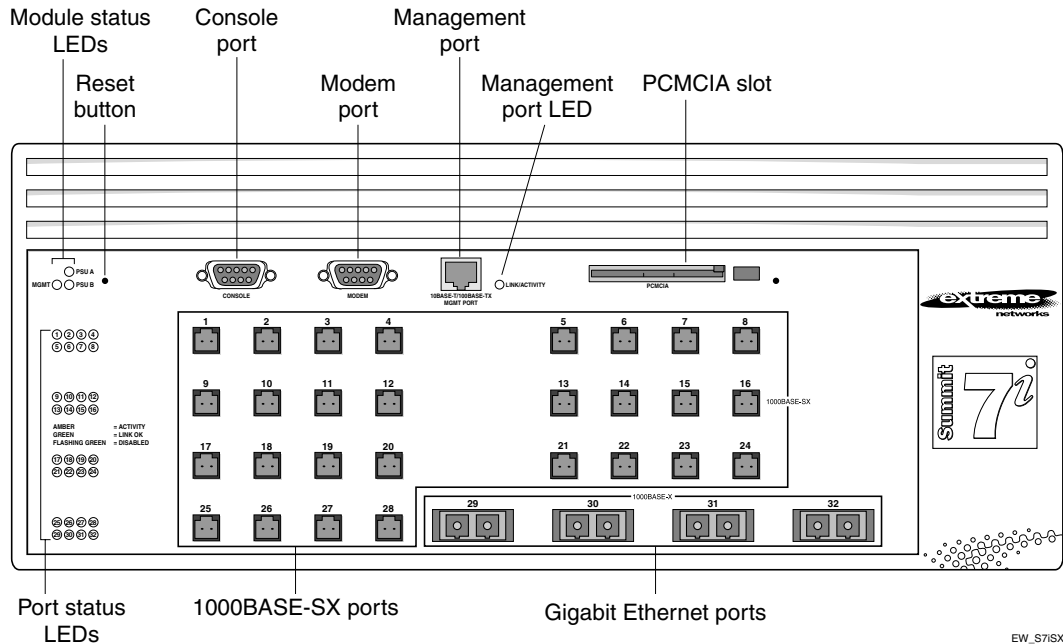

Figure 1-14: Front view of Summit7i switch with 1000BASE-SX ports

Both Summit7i switch models also provide four unpopulated GBIC ports with SC connectors. You can use any of the following GBICs in the Summit7i switch:

- 1000BASE-SX
- 1000BASE-LX
- 1000BASE-LX70



Note: For information on GBICs, refer to “GBIC Type and Hardware/Software Support,” on page 1-28.



Note: For information on supported media types and distances, refer to Table 1-2 on page 1-5.



Note: For information on Summit7i switch LEDs, refer to “Summit1i, Summit5i, Summit7i, and Summit48i Switch LEDs,” on page 1-27.

Reset Button

The reset button is used to hard reset the switch. Use a non-conductive tool to push the reset button.

Console Port

The console port (9-pin, “D” type connector) is used for connecting a terminal and carrying out local management.

Modem Port

The modem port is used to connect a modem for remote access to the command line interface (CLI).

Management Port

The management port (RJ-45 connector) is a 10/100 Mbps Ethernet connection used for out-of-band management.

PCMCIA Slot

The PCMCIA slot is reserved for future use.

Summit7i Switch Rear View

Figure 1-15 shows the rear view for the Summit7i switch.

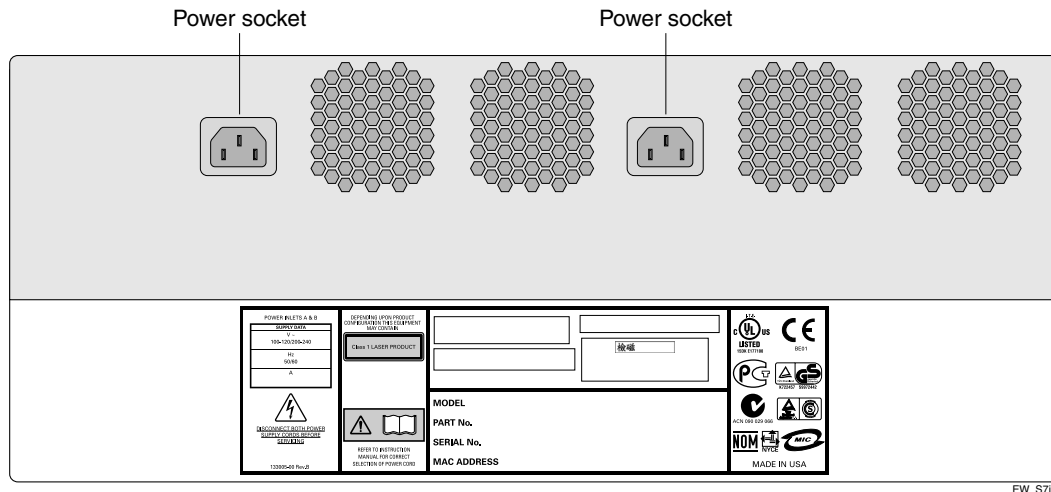

Figure 1-15: Summit7i switch rear view

Power Sockets

The Summit7i switch supports up to two power supplies. Each power supply has its own power socket. When a second power supply is installed, both provide a redundant, load-shared power source to the Summit7i switch. If one of the power sources fails, the second power supply takes over, ensuring uninterrupted network operation.



Note: Summit7i switch power supplies must only be serviced by personnel trained by Extreme Networks.

Serial Number

The serial number is used for fault-reporting purposes.

MAC Address

This label shows the unique Ethernet MAC address assigned to this device.

Summit48i Switch Front View

The Summit48i switch ships with 48 autosensing 10BASE-T/100BASE-TX ports.

Figure 1-16 shows the front view of the Summit48i switch.

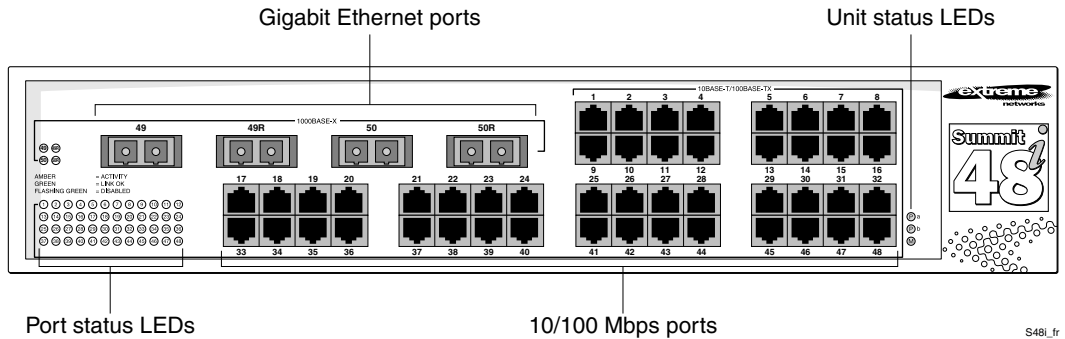

Figure 1-16: Front view of Summit48i switch

The Summit48i switch has 2 Gigabit Ethernet ports and 2 redundant Gigabit Ethernet ports. All the Gigabit Ethernet ports use GBIC connectors. You can use any of the following GBICs in the Summit48i switch:

- 1000BASE-SX
- 1000BASE-LX
- 1000BASE-LX70



Note: For information on GBICs, refer to “GBIC Type and Hardware/Software Support,” on page 1-28.



Note: For information on supported media types and distances, refer to Table 1-2 on page 1-5.



Note: For information on Summit48i switch LEDs, refer to “Summit1i, Summit5i, Summit7i, and Summit48i Switch LEDs,” on page 1-27.

Summit48i Switch Rear View

Figure 1-17 shows the rear view for the Summit48i switch.

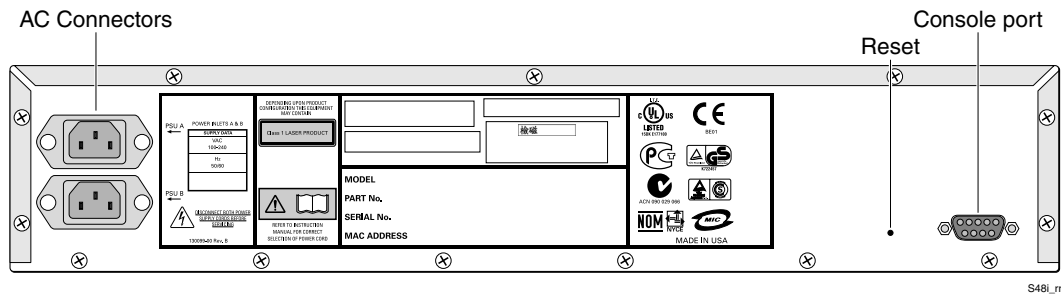

Figure 1-17: Summit48i switch rear view

Power Sockets

The Summit48i switch supports two power supplies. Each power supply has its own power socket. The power supplies provide a redundant, load-shared power source to the Summit48i switch.

If one of the power supplies fails, or if source power to one of the power supplies fails, the second power supply takes over, ensuring uninterrupted network operation. The switch also does the following:

- Send a message to the syslog telling you which power supply failed
- Send an SNMP trap to your network management software



Note: Summit48i switch power supplies must only be serviced by personnel trained by Extreme Networks.

Serial Number

The serial number is used for fault-reporting purposes.

MAC Address

This label shows the unique Ethernet MAC address assigned to this device.

Reset Button

The reset button is used to hard reset the switch. Use a non-conductive tool to push the reset button.

Console Port

The console port (9-pin, “D” type connector) is used for connecting a terminal and carrying out local management.

Summit1i, Summit5i, Summit7i, and Summit48i Switch LEDs

Table 1-5 describes the light emitting diode (LED) behavior on the Summit1i, Summit5i, Summit7i, and Summit48i switches.

Table 1-5: Summit1i, Summit5i, Summit7i, and Summit48i Switch LED Behavior

Unit Status LEDs		
LED	Color	Indicates
Power (A and B)	Green	The indicated power supply unit (PSU) is powered up.
	Yellow	The indicated PSU has a failure.
	Green/Yellow Flashing	The AC power cord is not inserted correctly.
	Off	The PSU is not receiving power or no PSU is present.
MGMT	Green flashing	
	<ul style="list-style-type: none"> ■ Slow ■ Fast 	<ul style="list-style-type: none"> The switch is operating normally. Power On Self Test (POST) or software download in progress.
	Yellow	The switch has failed its POST or is experiencing an overheat or fan failure.

Table 1-5: Summit1i, Summit5i, Summit7i, and Summit48i Switch LED Behavior**Port Status LEDs (bottom row for 100BASE-TX/1000BASE-T ports)**

Color	Indicates
Green	Link is present; port is enabled.
Yellow	Frames are being transmitted/received on this port.
Green flashing	Link is present; port is disabled.
Off	Link is not present.

100/1000 Mbps Speed LEDs (top row for 100BASE-TX/1000BASE-T ports)

Color	Indicates
Green	1000 Mbps
Off	100 Mbps

10/100 Management Port LED (right of 10BASE-T/100BASE-TX Management Port on Summit5i and Summit7i)

Color	Indicates
Green	Link is present.
Yellow	Frames are being transmitted.
Off	Link is not present.

GBIC Type and Hardware/Software Support

The switch supports two types of GBICs: the Parallel ID GBIC and the Serial ID GBIC. The system uses identifier bits to determine the media type for the GBIC that is installed. Initial ExtremeWare versions do not support Serial ID GBICs. If Serial ID GBICs are installed in a switch with an initial software release, the switch will not bring up the link on GBIC ports.

GBICs are used in these switches:

- Summit24
- Summit48
- Summit1i
- Summit5i
- Summit7i
- Summit48i

2

Installation and Setup

This chapter describes the following:

- How to decide where to install the Summit switch
- Gigabit Ethernet configuration rules
- How to install the switch in a rack or free-standing
- How to connect equipment to the console port
- How to check the installation using the Power On Self-Test (POST)



Caution: Use of controls or adjustments of performance or procedures other than those specified herein can result in hazardous radiation exposure.

Following Safety Information

Before installing or removing any components of the switch, or before carrying out any maintenance procedures, read the safety information provided in Appendix A of this guide.

Determining the Switch Location

The Summit switch is suited for use in the office, where it can be free-standing or mounted in a standard 19-inch equipment rack. Alternately, the device can be

rack-mounted in a wiring closet or equipment room. Two mounting brackets are supplied with the switch.

When deciding where to install the switch, ensure that:

- The switch is accessible and cables can be connected easily.
- Water or moisture cannot enter the case of the unit.
- Air-flow around the unit and through the vents in the side of the case is not restricted. You should provide a minimum of 25 mm (1 inch) clearance.
- No objects are placed on top of the unit.
- Units are not stacked more than four high if the switch is free-standing.

Installing the Summit Switch

The Summit switch can be mounted in a rack, or placed free-standing on a tabletop.

Rack Mounting



Caution: Do not use the rack mount kits to suspend the switch from under a table or desk, or to attach the switch to a wall.

To rack mount the Summit switch, follow these steps:

- 1 If you are installing a Summit7i switch, mount the helper bracket in the rack using four appropriate rack-mounting screws (not provided), as shown in Figure 2-1.



Note: Only the Summit7i switch uses the helper bracket. The helper bracket is not required to rack mount a Summit4, Summit4/FX, Summit24, Summit48, Summit1i, Summit5i, or Summit48i switch.

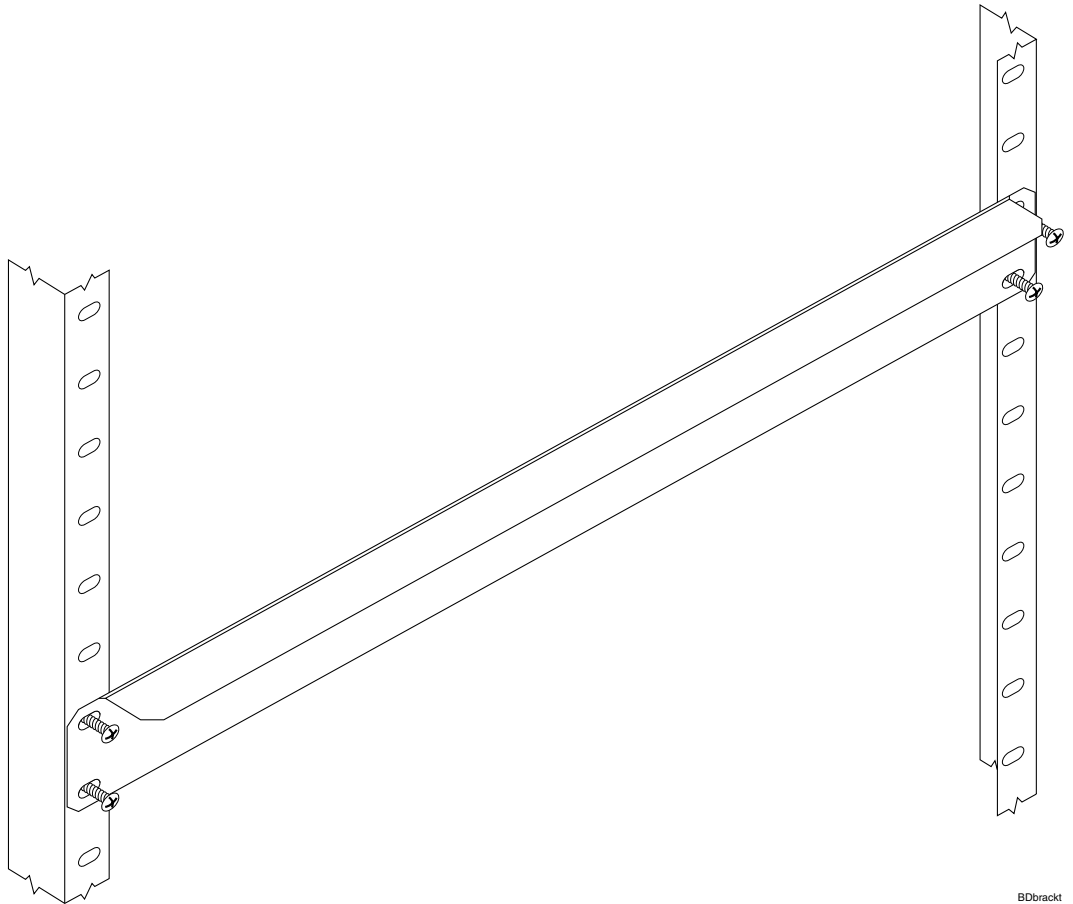
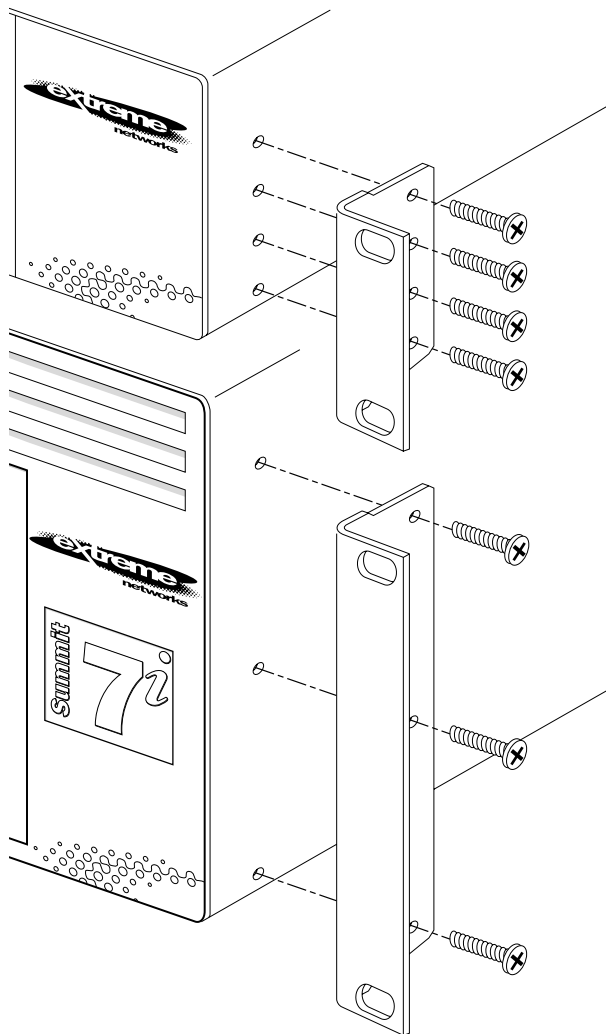

Figure 2-1: Rack-mount helper bracket

- 2 Place the switch upright on a hard flat surface, with the front facing you.
- 3 Remove the existing screws from the sides of the case (retain the screws for Step 5).
- 4 Locate a mounting bracket over the mounting holes on one side of the unit.
- 5 Insert the screws and fully tighten with a suitable screwdriver, as shown in Figure 2-2.



EW Rack

Figure 2-2: Fitting the mounting bracket

- 6 Repeat steps 3 - 5 for the other side of the switch.
- 7 Insert the switch into the 19 inch rack. If you are installing a Summit7i switch, place it on the helper bracket. Ensure that ventilation holes are not obstructed.
- 8 Secure the switch with suitable screws (not provided).

- 9 If you are installing a Summit7i switch, remove the helper bracket after the chassis is secured.
- 10 Connect the Summit switch to the redundant power supply (if applicable).
- 11 Connect cables.

Free-Standing

The Summit switch is supplied with four self-adhesive rubber pads. Apply the pads to the underside of the device by sticking a pad in the marked area at each corner of the switch.

Stacking the Switch and Other Devices

You can place up to four Summit switches on top of one another.



Note: This relates only to physically placing the devices on top of one another.

Apply the pads to the underside of the device by sticking a pad at each corner of the switch. Place the devices on top of one another, ensuring that the corners align.

Connecting Equipment to the Console Port

Connection to the console port is used for direct local management. The switch console port settings are set as follows:

- **Baud rate** — 9600
- **Data bits** — 8
- **Stop bit** — 1
- **Parity** — None
- **Flow control** — XON/XOFF

The terminal connected to the console port on the switch must be configured with the same settings. This procedure is described in the documentation supplied with the terminal.

Appropriate cables are available from your local supplier. To make your own cables, pinouts for a DB-9 male console connector are described in Table 2-1.

Table 2-1: Console Connector Pinouts

Function	Pin Number	Direction
DCD (data carrier detect)	1	In
RXD (receive data)	2	In
TXD (transmit data)	3	Out
DTR (data terminal ready)	4	Out
GND (ground)	5	-
DSR (data set ready)	6	In
RTS (request to send)	7	Out
CTS (clear to send)	8	In

Figure 2-3 shows the pin-outs for a 9-pin to RS-232 25-pin null-modem cable.

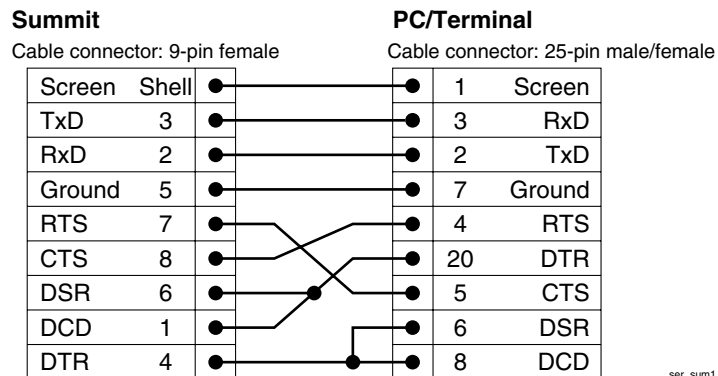

ser_sum1

Figure 2-3: Null-modem cable pin-outs

Figure 2-4 shows the pin-outs for a 9-pin to 9-pin PC-AT null-modem serial cable.

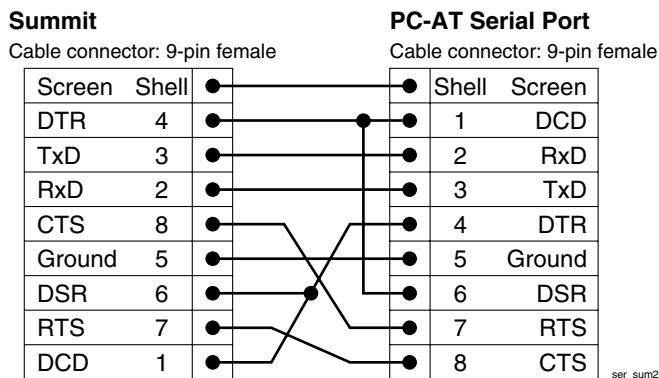

Figure 2-4: PC-AT serial null-modem cable pin-outs

Powering On the Switch

To turn on power to the switch, connect the AC power cable to the switch and then to the wall outlet. For the Summit4, Summit24, and Summit48 switches, turn the on/off switch to the on position.



Note: The Summit1i, Summit5i, Summit7i, and Summit48i switches do not have on/off switches.

Checking the Installation

After turning on power to the Summit switch, the device performs a Power On Self-Test (POST).

During the POST, all ports are temporarily disabled, the packet LED is off, the power LED is on, and the MGMT LED flashes. The MGMT LED flashes until the switch successfully passes the POST.

If the switch passes the POST, the MGMT LED blinks at a slow rate (1 blink per second). If the switch fails the POST, the MGMT LED shows a solid yellow light.



Note: For more information on the LEDs, refer to Chapter 1.

Logging In for the First Time

After the Summit switch completes the POST, it is operational. Once operational, you can log in to the switch and configure an IP address for the default VLAN (named *default*).

To manually configure the IP settings, perform the following steps:

- 1 Connect a terminal or workstation running terminal-emulation software to the console port.
- 2 At your terminal, press [Return] one or more times until you see the login prompt.
- 3 At the login prompt, enter the default user name *admin* to log on with administrator privileges. For example:

```
login: admin
```

Administrator capabilities allow you to access all switch functions.



Note: For more information on switch security, refer to the ExtremeWare User Guide.

- 4 At the password prompt, press [Return].

The default name, *admin*, has no password assigned. When you have successfully logged on to the switch, the command-line prompt displays the name of the switch (for example, *Summit24*) in its prompt.

- 5 Assign an IP address and subnetwork mask for VLAN *default* by typing

```
config vlan default ipaddress 123.45.67.8 255.255.255.0
```

Your changes take effect immediately.

- 6 Save your configuration changes so that they will be in effect after the next switch reboot, by typing

```
save
```



Note: For more information on saving configuration changes, refer to the ExtremeWare Software User Guide.

- 7 When you are finished using the facility, logout of the switch by typing

```
logout
```



Note: After two incorrect login attempts, the Summit switch locks you out of the login facility. You must wait a few minutes before attempting to log in again.

Installing the Gigabit Interface Connector (GBIC)

GBICs can be added and removed from the switch without powering off the system. The two types of GBIC modules are shown in Figure 2-5.

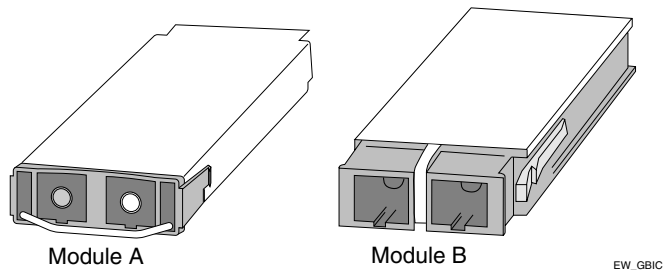

Figure 2-5: GBIC modules

GBICs are a Class 1 laser device. Use only Extreme-approved devices.



Note: Ensure that the SC fiber-optic connector is removed from the GBIC prior to removing the GBIC from the I/O module.



Caution: Invisible laser radiation can occur when open. Avoid direct eye exposure to beam.

To remove the GBIC module labeled “Module A,” lift up on the front handle and pull the GBIC out of the slot.

To remove the GBIC module labeled “Module B,” gently squeeze the sides to release it, and pull the GBIC out of the slot.

To insert a GBIC module, follow these steps:

- 1 Holding the GBIC by its sides, insert the GBIC into the slot on the I/O module.
- 2 Slide the GBIC as far back into the slot as possible, until you hear it click.
- 3 If the GBIC has a handle, push down on the handle to secure the GBIC in the slot.



Safety Information

Important Safety Information



Warning: Read the following safety information thoroughly before installing the Summit switch. Failure to follow this safety information can lead to personal injury or damage to the equipment.

Installation, maintenance, removal of parts, and removal of the unit and components must be done by qualified service personnel only.

Service personnel are persons having appropriate technical training and experience necessary to be aware of the hazards to which they are exposed in performing a task and of measures to minimize the danger to themselves or other persons.

Install the unit only in a temperature- and humidity-controlled indoor area free of airborne materials that can conduct electricity. Too much humidity can cause a fire. Too much dryness can produce electrical shock and fire.

Power

The unit must be grounded. Do not connect the power supply unit to an AC outlet without a ground connection.

The unit must be connected to a grounded outlet to comply with European safety standards.

This unit operates under Safety Extra Low Voltage (SELV) conditions according to IEC 950. The conditions are only maintained if the equipment to which it is connected also operates under SELV conditions.

The appliance coupler (the connector to the unit and not the wall plug) must have a configuration for mating with an EN60320/IEC320 appliance inlet.

France and Peru only: This unit cannot be powered from IT+ supplies. If your supplies are of IT type, this unit must be powered by 230 V (2P+T) via an isolation transformer ratio 1:1, with the secondary connection point labeled Neutral, connected directly to ground.

Power Cord

This must be approved for the country where it is used:

- USA and Canada
 - The cord set must be UL-listed and CSA-certified.
 - The minimum specification for the flexible cord is No. 18 AWG (1.5 mm²), Type SVT or SJT, 3-conductor.
 - The cord set must have a rated current capacity of at least 10 A.
 - The attachment plug must be an Earth-grounding type with a NEMA 5-15P (10 A, 125 V) configuration.
- Denmark
 - The supply plug must comply with section 107-2-D1, standard DK2-1a or DK2-5a.
- Switzerland
 - The supply plug must comply with SEV/ASE 1011.
- Argentina
 - The supply plug must comply with Argentinian standards.

Fuse

Disconnect power from the unit before opening the fuse holder cover. The unit automatically adjusts to the supply voltage. The fuse is suitable for both 110 VAC and 200-240 VAC operation.

To change the fuse, release the fuse holder by gently levering a small screwdriver under the fuse holder catch. Use only fuses of the same manufacturer, rating, and type as the original. Close the fuse holder.



Note: The fuse on the Summit7i switch is not user-replaceable.

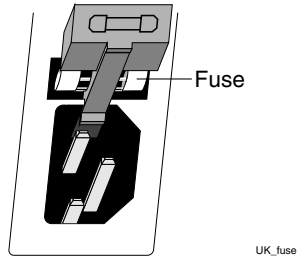

To comply with European safety standards, a spare fuse must not be fitted to the appliance inlet. Use only fuses of the same manufacturer, make, and type.

Connections

Fiber Optic ports - Optical Safety. Never look at the transmit LED/laser through a magnifying device while it is powered on. Never look directly at the fiber TX port and fiber cable ends when they are powered on.

CLASS 1 LASER DEVICE



Warning: Use only for data communications applications that require optical fiber. Use only with the appropriate connector. When not in use, replace dust cover. Using this module in ways other than those described in this manual can result in intense heat that can cause fire, property damage, or personal injury.

Lithium Battery

The battery in the bq4830/DS1644 device is encapsulated and not user-replaceable.

If service personnel disregard the instructions and attempt to replace the bq4830/DS1644, replace the lithium battery with the same or equivalent type, as recommended by the manufacturer.



Warning: Danger of explosion if battery is incorrectly replaced. Replace only with the same or equivalent type recommended by the manufacturer. Dispose of used batteries according to the manufacturer's instructions.

Disposal requirements vary by country and by state. Lithium batteries are not listed by the Environmental Protection Agency (EPA) as a hazardous waste. Therefore, they can typically be disposed of as normal waste. If you are disposing of large quantities, contact a local waste-management service.

No hazardous compounds are used within the battery module. The weight of the lithium contained in each coin cell is approximately 0.035 grams.

Two types of batteries are used interchangeably:

- CR chemistry uses manganese dioxide as the cathode material.
- BR chemistry uses poly-carbonmonofluoride as the cathode material.

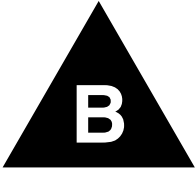

Technical Specifications

Summit4, Summit4/FX, Summit24, and Summit48 Switch Specifications

The following table lists specifications for the Summit4, Summit4/FX, Summit24, and Summit48 switch.

Physical Dimensions	Height: 3.5 inches (8.9 cm) Width: 17.32 inches (44 cm) Depth: 17.32 inches (44 cm) Weight: 22 lbs (10 kg)
Environmental Requirements	
Operating Temperature	0 to 40° C
Storage Temperature	-10 to 70° C
Operating Humidity	10% to 95% relative humidity, noncondensing
Standards	EN60068 (IEC68)
Safety	
Agency Certifications	UL 1950 3rd Edition, listed cUL listed to CSA 22.2#950 TUV GS mark & GOST safety approval to the following EN standards: <ul style="list-style-type: none">■ EN60950:1992/A3:1995 plus Deviations■ EN60825-1; 1994, all 1996 ZB/ZC

Electromagnetic Compatibility	FCC part 15 Class A CSA C108.8-M11983 (A) VCCI Class A EN55022 Class A EN50082 -1 (1997) C-Tick mark to AS/NZS 3548:1995
Heat Dissipation	135 W maximum (341.2 BTU/hr maximum)
Power Supply	
AC Line Frequency	50 Hz to 60 Hz
Input Voltage Options	90 VAC to 264 VAC, auto-ranging
Current Rating	100-120/200-240 VAC 3.0/1.5 A

Summit1i, Summit5i, Summit7i, and Summit48i Switch Specifications

The following table lists the specifications for the Summit1i, Summit5i, Summit7i, and Summit48i switches.

Physical Dimensions

Summit1i

Height: 3.5 inches (8.9 cm)
Width: 17.25 inches (43.8 cm)
Depth: 19.0 inches (48.3 cm)
Weight: 22 lbs (10 kg)

Summit5i

Height: 3.5 inches (8.9 cm)
Width: 17.25 inches (43.8 cm)
Depth: 19.0 inches (48.3 cm)
Weight (single power supply): 21.7 lbs (9.8 kg)
Weight (dual power supply): 27.4 lbs (12.4 kg)

Summit7i

Height: 7.0 inches (17.8 cm)
Width: 17.25 inches (43.8 cm)
Depth: 19.0 inches (48.3 cm)
Weight (single power supply): 45 lbs (20.4 kg)
Weight (dual power supply): 55 lbs (24.9 kg)

Summit48i

Height: 3.5 inches (8.9 cm)
Width: 17.25 inches (43.8 cm)
Depth: 19.0 inches (48.3 cm)
Weight: 24 lbs (10.8 kg)

Environmental Requirements

Operating Temperature	0 to 40° C
Storage Temperature	-10 to 70° C
Operating Humidity	10% to 95% relative humidity, noncondensing
Standards	EN60068 to Extreme IEC68 schedule

Certification Marks



CE (European Community)



TUV/GS (German Notified Body)



TUV/S (Argentina)



GOST (Russian Federation)



C-Tick (Australian Communication Authority)



Underwriters Laboratories (USA and Canada)



MIC (South Korea)



NOM (Mexican Official Normalization, Electronic Certification and Normalization)

Safety

Agency Certifications

UL 1950 3rd Edition, listed
EN60950:1992/A1-4:1997 plus ZB/ZC Deviations
IEC 950CB
Low Voltage Directive (LVD)
CSA 22.2#950-95
AS/NZS 3260
EN60825-1
FCC CFR 21

**Electromagnetic Interference/
Compatibility (EMI/EMC)**

FCC CFR 47 part 15 Class A
ICES-0003 A/C108.8-M1983 Class A
VCCI Class A
AS/NZS 3548
EN55022 Class A
CISPR 22 Class A
EN50082 -1:1997 include ENV 50204
EN55024:1998 includes IEC 61000-4-2, 3, 4, 5, 6, 8, 11
EN 61000-3-2, 3
CNS 13438 Class A

Heat Dissipation**Summit1i**

91 W maximum (311 BTU/hr maximum)

Summit5i

287 W maximum (979 BTU/hr maximum)

Summit7i

372 W maximum (1272 BTU/hr maximum)

Summit48i

136 W maximum (464 BTU/hr maximum)

Power Supplies

Summit1i

AC Line Frequency: 50 Hz to 60 Hz

Input Voltage Options: 85 VAC to 250 VAC

Current Rating: 100-120/200-240 VAC 3/1.5 A

Summit5i

AC Line Frequency: 50 Hz to 60 Hz

Input Voltage Options: 100 VAC to 240 VAC

Current Rating: 100-120/200-240 VAC 4/2

Summit7i

AC Line Frequency: 50 Hz to 60 Hz

Input Voltage Options: 90 VAC to 264 VAC

Current Rating: 100-120/200-240 VAC 10/5 A

Summit48i

AC Line Frequency: 50 Hz to 60 Hz

Input Voltage Options: 85 VAC to 250 VAC

Current Rating: 100-120/200-240 VAC 3/1.5 A

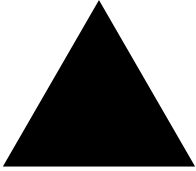

Index

A

agency certifications B-4

C

cable types and distances 1-5
certification marks B-1, B-3
console port
 connecting equipment to 2-5
 location 1-11, 1-15, 1-19, 1-22, 1-26
conventions
 notice icons xii
 text xii

D

dimensions, Summit switch B-1, B-2

E

electromagnetic compatibility B-2, B-4
environmental requirements B-1, B-3

F

free-standing installation 2-5
full-duplex 1-6

G

GBICs, installing and removing 2-9

H

hardware address 1-12, 1-16, 1-19, 1-24, 1-26
heat dissipation B-2, B-4
helper bracket, installing 2-2

I

installation
 free-standing 2-5
 GBICs 2-9
 helper bracket 2-2
 rack 2-2
 verifying 2-7

L

LEDs, behavior 1-12, 1-27
logging in 2-8

M

MAC address 1-12, 1-16, 1-19, 1-24, 1-26
management port 1-20, 1-23
media types and distances 1-5
modem port 1-23

P

port
 connections 1-3
 redundant power supply 1-11
power socket 1-11, 1-15, 1-19, 1-24, 1-26
power supply 1-11, 1-15, 1-19, 1-24, 1-26

power supply specifications B-2, B-5
 powering on the switch 2-7

R

rack mounting the switch 2-2
 redundant power supply port 1-11
 related publications xiii
 reset button 1-12, 1-16, 1-20, 1-23, 1-27

S

safety information A-1
 serial number 1-11, 1-16, 1-19, 1-24, 1-26
 serial port. *See* console port
 show memory 1-3
 size, Summit switch B-1, B-2
 socket, power 1-11, 1-15, 1-19, 1-24, 1-26
 Summit switch, general
 features 1-2
 free-standing installation 2-5
 installing 2-2
 location 2-1
 media distances, supported 1-5
 media types, supported 1-5
 models 1-1
 port connections 1-3
 powering on 2-7
 rack mounting 2-2
 stacking with other devices 2-5
 verifying the installation 2-7
 Summit1i switch
 agency certifications B-4
 certification marks B-3
 console port location 1-15
 dimensions B-2
 electromagnetic compatibility B-4
 environmental requirements B-3
 front view 1-14
 GBIC support 1-15
 heat dissipation B-4
 LEDs 1-27
 MAC address 1-16
 port configurations 1-14
 power supply 1-15
 power supply specifications B-5
 rear view 1-15
 reset button 1-16
 serial number 1-16
 size B-2
 weight B-2
 Summit24 switch
 certification marks B-1
 console port 1-11
 dimensions B-1
 electromagnetic compatibility B-2
 environmental requirements B-1

front view 1-9
 heat dissipation B-2
 LEDs 1-12
 MAC address 1-12
 power supply 1-11
 power supply specifications B-2
 rear view 1-11
 redundant power supply port 1-11
 reset button 1-12
 serial number 1-11
 size B-1
 weight B-1

Summit4 switch

certification marks B-1
 console port 1-11
 dimensions B-1
 electromagnetic compatibility B-2
 environmental requirements B-1
 front view 1-7
 heat dissipation B-2
 LEDs 1-12
 MAC address 1-12
 power supply 1-11
 power supply specifications B-2
 rear view 1-11
 redundant power supply port 1-11
 reset button 1-12
 serial number 1-11
 size B-1
 weight B-1

Summit4/FX switch

front view 1-8

Summit48 switch

certification marks B-1
 console port 1-11
 dimensions B-1
 electromagnetic compatibility B-2
 environmental requirements B-1
 front view 1-10
 heat dissipation B-2
 LEDs 1-12
 MAC address 1-12
 power supply 1-11
 power supply specifications B-2
 rear view 1-11
 redundant power supply port 1-11
 reset button 1-12
 serial number 1-11
 size B-1
 weight B-1

Summit48i switch

agency certifications B-4
 certification marks B-3
 console port location 1-26
 dimensions B-2
 electromagnetic compatibility B-4
 environmental requirements B-3

front view	1-25
GBIC support	1-25
heat dissipation	B-4
LEDs	1-27
MAC address	1-26
port configurations	1-25
power supply	1-26
power supply specifications	B-5
rear view	1-26
reset button	1-27
serial number	1-26
size	B-2
weight	B-2
Summit5i switch	
agency certifications	B-4
certification marks	B-3
console port location	1-19
dimensions	B-2
electromagnetic compatibility	B-4
environmental requirements	B-3
front view	1-17
GBIC support	1-18
heat dissipation	B-4
LEDs	1-27
MAC address	1-19
management port	1-20
port configurations	1-17
power supply	1-19
power supply specifications	B-5
rear view	1-19
reset button	1-20
serial number	1-19
size	B-2
weight	B-2
Summit7i switch	
agency certifications	B-4
certification marks	B-3
console port location	1-22
dimensions	B-2
electromagnetic compatibility	B-4
environmental requirements	B-3
front view	1-21
GBIC support	1-22
heat dissipation	B-4
LEDs	1-27
MAC address	1-24
management port	1-23
modem port	1-23
port configurations	1-21
power supply	1-24
power supply specifications	B-5
rear view	1-24
reset button	1-23
serial number	1-24
size	B-2
weight	B-2

V

verifying the installation	2-7
----------------------------	-----

W

weight, Summit switch	B-1, B-2
-----------------------	----------